

B-B
1.5 : 1

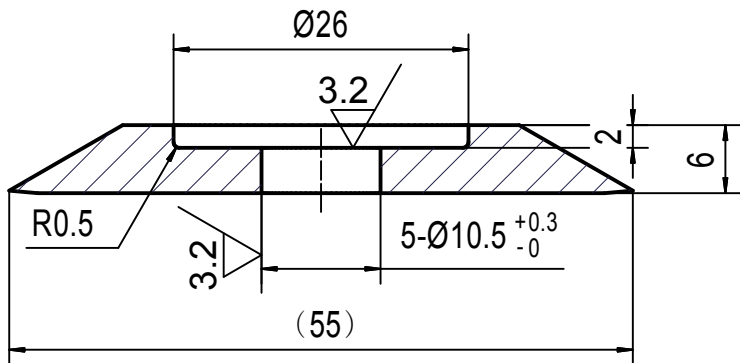

A
5 : 1

